



TLDD-35V



LDD-14V



LDD-23V



TLDD-23V

Our Premier LEAF VACUUMS



THERE'S POWER
THEN THERE'S FRADAN POWER

WWW.FRADANPOWER.COM

• LEAF VACUUM •

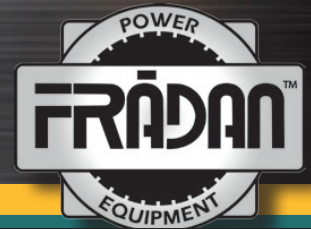

FRADAN
TLDD-35V



Most Power, Best Price: Meet the Future of All Truckloaders

Fradan's newly-designed Direct Discharge 35HP Truckloader, model TLDD-35V, is the new gold standard in truckloaders. In this model, sleek, lightweight, and compact design meets incredible power, all at an amazing price point.

This new model, easy to transport and store, features a belt-driven torque multiplier produces 70 foot pounds of torque at the fan. This powerful machine is ideal for the commercial user. The location of the shredding impeller is strategically placed away from the engine, protecting it from debris impacts. The result? More engine longevity.

This cost-effective model is also available in a skid mount, remaining at an unbelievable price point. No matter which style (skid or trailer) you choose, the impact of this machine is undeniable: extreme value, quality, efficiency, a longer lifespan, and top notch power—all the qualities you've come expect from Fradan.

Newly improved Shredding Blades will cut through and shred leaves to a 15:1 compaction ration. Tapper locking hub and built in wheel pulley makes removing impeller a breeze. Longer lasting blades 1/2inch thick and a bigger 21inch diameter will outperform the competition.

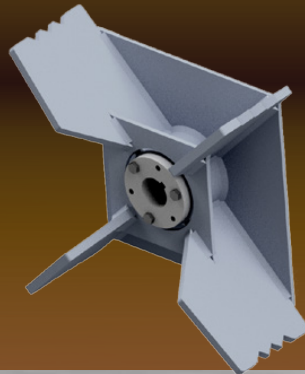

TLDD-35V

ENGINE- 35 HP VG
DISPLACEMENT 993cc

Drive system
Belt driven torque multiplier

Turnkey Electric Starter

IMPELLER- 21inch diameter
Reinforced blades, 1/2inch steel

FUEL CAPACITY-6 gal

TIRE SIZE -ST 205-75 D15

Heavy Duty LED LIGHTS

SUCTION HOSE- 14"x10'

DISCHARGE HOSE- 10"x6'

TOW BAR- Standard Pintle
(optional 2" and 2-5/16" Ball Hitch)

HITCH HEIGHT- 18" to 25"
Adjustable

HITCH CLASS
REQUIREMENTS
Class III

WHEEL BASE-57"

SUSPENSION- Torsion Bar

DIMENSIONS- 88"x 57"x 118" (LxWxH)

DRY WEIGHT- 1330 lbs

PLEASE NOTE: All specifications are subject to change without prior notice.

THEN THERE'S FRADAN POWER

WWW.FRADANPOWER.COM

• LEAF VACUUM •



FRADAN
TLDD-23V

Most Power, Best Price: Meet the Future of All Truckloaders

Fradan's newly Designed Direct Discharge Truckloader with its Multi-Torque drive system produces 38 Foot LBS of Torque. Do not let its 627cc engine fool you this High torque truckloader can outperform its bigger engine competition. This model is compact and at an untouchable price point.

Newly improved Shredding Blades will cut through and shred leaves to a 15:1 compaction ration. Tapper locking hub and built-in wheel puller makes removing impeller a breeze. Longer lasting blades 3/8 inch thick and a larger diameter impeller will outperform the competition.

This is also available as a skid mount model LDD-23V.

Newly improved Shredding Blades will cut through and shred leaves to a 15:1 compaction ration. Tapper locking hub and built in wheel pulley makes removing impeller a breeze. Longer lasting blades 3/8inch thick and a bigger 19 inch diameter will outperform the competition.

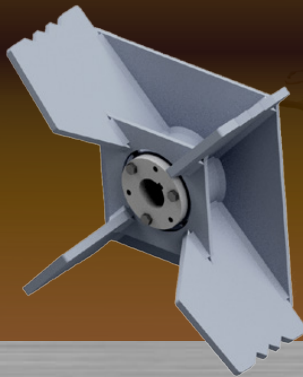

TLDD-23V

ENGINE- 23 HP VG
DISPLACEMENT 627cc

Drive system
Belt driven torque multiplier

Turnkey Electric Starter

IMPELLER- 19 inch diameter
Reinforced blades, 3/8 inch steel

FUEL CAPACITY-2.25 gal

TIRE SIZE -ST 205-75 D15

Heavy Duty LED LIGHTS

SUCTION HOSE- 12"x10'

DISCHARGE HOSE- 8" X 6'

TOW BAR- Standard Pintle
(optional 2" and 2-5/16" Ball Hitch)

HITCH HEIGHT- 18" to 25"
Adjustable

HITCH CLASS
REQUIREMENTS
Class III

WHEEL BASE-57"
SUSPENSION- Torsion Bar
DIMENSIONS- 87" x 57" x 115"
DRY WEIGHT- 922 lbs

PLEASE NOTE: All specifications are subject to change without prior notice.

THEN THERE'S FRADAN POWER

WWW.FRADANPOWER.COM

• LEAF VACUUM •



FRADAN
LDD-14V

Powerful and Torquey: Meet the Future of All Truckloaders

Fradan's newly Designed Direct Discharge Truckloader with its Multi-Torque drive system produces 26 Foot LBS of Torque. Do not let its 408cc engine fool you this High torque truckloader can outperform its bigger engine competition. This model is compact and at an untouchable price point.

Newly improved Shredding Blades will cut through and shred leaves to a 15:1 compaction ration. Tapper locking hub and built-in wheel pulley makes removing impeller a breeze. Longer lasting blades 5/16inch thick and a larger diameter impeller will outperform the competition.

Newly improved Shredding Blades will cut through and shred leaves to a 15:1 compaction ration. Tapper locking hub and built in wheel pulley makes removing impeller a breeze. Longer lasting blades 5/16 inch thick and a bigger 17 inch diameter will outperform the competition.

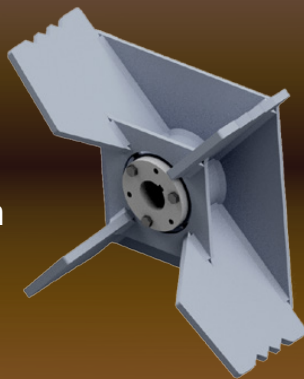

LDD-14V

ENGINE- 14 HP VG
DISPLACEMENT 408

DRIVE SYSTEM
Belt driven torque multiplier

TURNKEY ELECTRIC STARTER

IMPELLER- 17inch diameter
Reinforced blades, 5/16 inch steel

FUEL CAPACITY-1.5 gal

SUCTION HOSE- 10"x10'

DISCHARGE HOSE- 8 X 6

DIMENSIONS- 44" x 28" x 70"
DRY WEIGHT- 415 lbs

PLEASE NOTE: All specifications are subject to change without prior notice.

THEN THERE'S FRADAN POWER

WWW.FRADANPOWER.COM