



# OPERATORS MANUAL

## STRING TRIMMER MODEL ST-26



## STICK EDGER MODEL SE-26



**WARNING**



**DANGER**

Read instructions carefully  
and follow rules for safe operation.  
Failure to do so could result in serious injury

PART NO. 800-101-666-0

**FRADAN MANUFACTURING CORP**

499 Fifth Avenue, New Rochelle, NY 10801 • Phone (914) 632-3769 • Fax (914) 632-1652

# WELCOME TO THE FRADAN FAMILY

Congratulations, you are now the owner of a quality **FRADAN TRIMMER/BRUSHCUTTER**. **FRADAN** manufactures a family of high performance, reliable power equipment. Our designs are based on years of personal use of landscape equipment.

We at Fradan have revolutionized the landscaping industry, offering modern, reliable, high performance equipment designed to meet today's environmental demands and exceed tomorrow's.

**FRADAN** built means durability, quality, maximum performance and non-obsolescence. With proper care and maintenance of your unit, we assure you years of service-free operation. This booklet refers to the information which you should learn in order to take advantage of its outstanding performance.

**FRADAN** manufacturing, would like to thank you for choosing our product and hope that you continue to enjoy the quality and pride that we built into our products. Always use the proper machine for the job, use **FRADAN**.

## CONTENTS

Introduction/Technical Data . . . . .	3
Graphic Warnings . . . . .	4
Safety Rules & Precautions . . . . .	5-6
ST-26 Description . . . . .	7-8
SE-26 Description . . . . .	9-10
Assembly ST-26 . . . . .	11
Assembly SE-26 . . . . .	12
Rules for Safe Operation . . . . .	13
Cutting with a Nylon Head . . . . .	14-15
Fuel & Oil Mixture . . . . .	16
Preparing for Operations . . . . .	17
Operations . . . . .	18
Maintenance & Care . . . . .	19
Trouble Shooting . . . . .	20
For Your Records . . . . .	21

## INTRODUCTION

The FRADAN TRIMMER/BRUSH CUTTER is a ruggedly built, high performance gasoline powered unit specially designed for trimming and cutting grass, weeds and low growth. Proper maintenance and use of the FRADAN TRIMMER/BRUSH CUTTER will guarantee years of safe, service free, reliable operation. We wish for you to gain sufficient knowledge from this booklet before operating your FRADAN TRIMMER/BRUSH CUTTER and make the best use of it in the future. We urge you to follow these instructions to assure safe and reliable operation.



## TECHNICAL DATA

MODEL	ST-26	SE-26
Engine	Air Cooled 2 Stroke Single Cylinder	
Displacement	25.4 cc/1.55 cu. in	25.4 cc/1.55 cu. in
Carburetor	All position diaphragm type and purge	
Ignition	Fly Wheel Magneto (Electronic Ignition System)	
Clutch	Automatic Centrifugal - Type	
Starter	Recoil Starter	
Spark Plug	Champion RCJ6Y or Equivalent	
Tank Capacity	24 fl.oz / 710 ml.	24 fl.oz / 710 ml.
Mixing Ratio	32:1	
Gear Ratio	1.30 - 1	1.30-1
Operating Engine Speed	R.P.M. 3000-8000	
Dimensions	72x9x12 in 183x.23x.30 cm	70x16x12 in 178x.41x.30 cm
Weight	10.5 lb / 4.76 kg.	12.6 lb / 5.71 kg. .

## GRAPHIC WARNINGS

Because a trimmer/cutter is a high-speed, fast cutting power tool, special safety precaution must be observed to reduce the risk of personal injury. Read this manual carefully. Be familiar with the controls and the proper use of the unit. Know how to shut it off, and how to unhook a harnessed unit quickly.



This graphic accompanied by the words **WARNING** and **DANGER** calls attention to an act or a condition which can lead to **SERIOUS INJURY**.



**READ & UNDERSTAND** Operator's Manual and Safety Manual.



**ALWAYS WEAR EYE AND EAR PROTECTION**



Always **TURN OFF ENGINE** and make sure the cutting tool has stopped before cleaning, removing or adjusting blade.



**WARNING!** Never modify a trimmer or cutter in any way. Improper use of any trimmer can cause **SERIOUS OR FATAL PERSONAL INJURY**.

**WARNING**  **DANGER**

The engine exhaust from this product contains chemicals known to the State of California to cause cancer, birth defects, or other reproductive harm.

Specifications, descriptions and illustrative material in this manual are as accurate as known at the time of publication, but are subject to change without notice. Illustrations may include optional equipment and accessories, and may not include all standard equipment.



## SAFETY RULES AND PRECAUTIONS

- Proper safety precautions must be observed. Like all power equipment this unit must be handled carefully. **DO NOT EXPOSE YOURSELF OR OTHERS TO DANGER.** Follow these general rules. Do not permit others to use this machine unless they are thoroughly responsible and have read, and understand the machine manual and are trained in its operation.
- Always wear safety goggles for eye protection. Dress properly, do not wear loose clothing or jewelry that could become caught in the moving parts of the unit. Safe, sturdy, nonskid footwear should always be worn. Long hair should be tied back. It is recommended that legs and feet be covered to protect from flying debris during operation.
- Inspect the entire machine for loose parts (nuts, bolts, screws, etc.) and any damage. Repair or replace as necessary before using the machine.
- **DO NOT USE** any attachment with this power head other than the ones recommended by FRADAN. Serious injury to the operator or bystanders could result as well as damage to the machine.
- Keep the handles free from oil and fuel.
- Always use proper handle and shoulder strap when cutting.
- Do not smoke while mixing fuel or filling tank.
- Do not mix fuel in an enclosed room or near open flames. Assure adequate ventilation.
- Always mix and store the fuel in a properly marked container that is approved by local codes and ordinances for such usage.
- Never remove the fuel tank cap while the engine is running.
- Never start or run the engine inside a closed room or building. Fumes from the exhaust contain dangerous carbon monoxide.
- Never attempt to make engine adjustments while the unit is running and strapped to the operator. Always make engine adjustments with the unit resting on a flat, clear surface.
- Do not use the unit if it is damaged or poorly adjusted. Never remove the machine's guard.
- Inspect the area to be cut and remove all debris that could become entangled in the nylon cutting head. Also remove any objects that the unit may throw during cutting.
- Keep children away. Onlookers should be kept at a safe distance from the work area, at least 50 FEET.
- Never leave the machine unattended.
- Do not use this unit for any job other than those for which it is intended as described in this manual.
- Do not overreach. Keep proper footing and balance at all times. Do not run the unit while standing on a ladder or on any unstable footing location.
- Keep hands and feet clear of the nylon cutting head while unit is in use.
- Do not use this type of machine for sweeping away debris.
- Do not use the unit when you are tired or under the influence of medication, drugs or alcohol.

- Use nylon cutting head which is free of damage. If a stone or any other obstacle is hit, stop the engine and check the nylon cutting head. A broken or unbalanced nylon cutting head must never be used.  
**FOLLOW INSTRUCTION FOR CHANGING ACCESSORIES.**
- Do not store in a closed area where fuel vapors can reach an open flame from hot water heaters, furnaces, etc. Store in a locked, well ventilated area only.
- Use only FRADAN original equipment parts when servicing the unit. This will ensure safe and proper performance of your product. These parts are available from your dealer. The use of any other accessories or attachments may cause a potential hazard or injury to the user, damage to the machine and void this warranty.
- Clean the machine completely, especially, the fuel tank, its surroundings, and the air cleaner.
- When refueling, be sure to stop the engine and confirm that it is cooled down. Never refuel when the engine is running hot. When gasoline spills, be sure to wipe it up completely and properly dispose of those materials before starting the engine.
- Stay clear of the other workers or bystanders by at least 15 meters/50 feet.
- When ever approaching an operator of the machine, carefully call his attention and confirm that the operator stops the engine. Be careful not to startle or distract the operator which can cause an unsafe situation.
- Never touch the nylon cutting head when ever the engine is running. If it is necessary to adjust the protector or nylon cutting head, be sure to stop the engine and confirm that the nylon cutting head has stopped running.
- The engine should be turned off when the machine is moved between work areas.
- Be careful not to hit the nylon cutting head against stones, or the ground. Unreasonable rough operation will shorten the life of the machine as well as create an unsafe environment for yourself and those around you.
- Pay attention to loosening and overheating of parts. If there is any abnormality of the machine, stop operation immediately and check the machine carefully. If necessary, have the machine serviced by a authorized FRADAN dealer. Never continue to operate a machine which may be malfunctioning.
- In start-up or during operation of the engine, never touch hot parts such as the muffler, the high voltage wire or the spark plug.
- After the engine has stopped, the muffler is still hot. Never place the machine in any places where there are flammable materials (dry grass, etc.), combustible gases or combustible liquids.
- Pay special attention to operation in the rain or just after the rain as the ground may be slippery.
- If you slip or fall to the ground or into a hole, release the throttle lever immediately.
- Be careful not to drop the machine or hit it against obstacles.
- Before proceeding to adjust or repair the machine, be sure to stop the engine and detach the spark plug cap from the spark plug.
- When the machine is placed in storage for a long time, drain fuel from the fuel tank and carburetor, clean the parts, move the machine to a safe place and confirm that the engine is cooled down.
- Make periodic inspections to assure safe and efficient operation. For a thorough inspection of your machine, please contact a FRADAN dealer.
- Keep the machine away from fire or sparks.
- **WARNING:** The cutter area is still dangerous while the machine is coasting to a stop.

# DESCRIPTION ST-26

## STRING TRIMMER ST-26

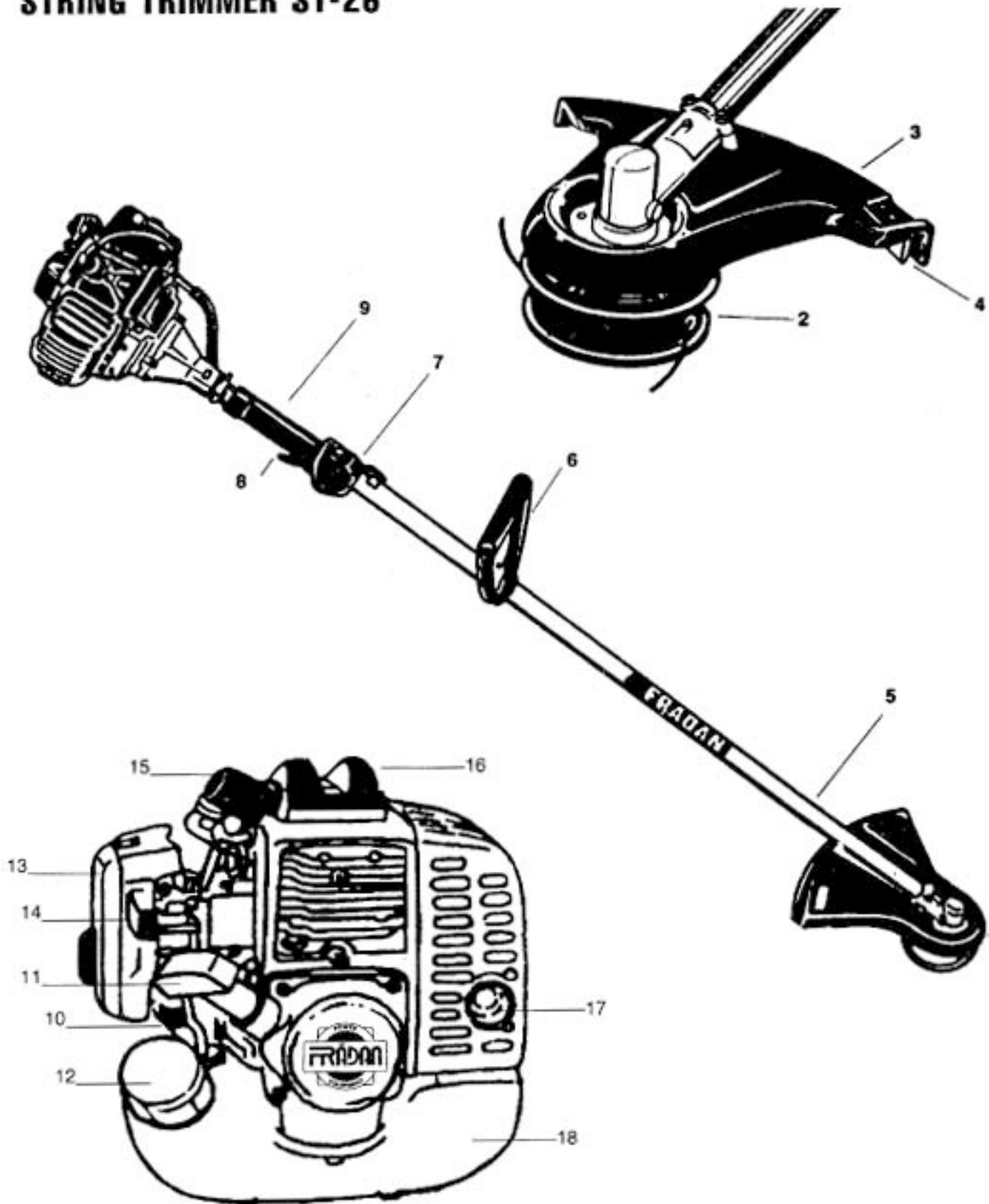



## DESCRIPTION ST-26

- 1. SAFETY MANUAL** Included with unit. Read before operating and keep for future reference to learn proper, safe operating techniques.
- 2. NYLON CUTTING HEAD** Contains replaceable nylon trimming line that advances when the trimmer head is tapped against the ground while the head is turning at normal operating speed.
- 3. DEBRIS SHIELD** Mounted just above the cutting attachment. Helps protect operator by deflecting debris produced during the trimming operation. Do not operate unit without shield.
- 4. CUT-OFF KNIFE** Trims nylon filament to the correct length - 7", head to end of line- when nylon trimming head is bumped on the ground during operation, line advances. If trimmer is operated without a cut-off knife the line becomes too long (more than 7") the operating speed will slow down the engine. This will overheat or damage the engine.
- 5. DRIVE SHAFT ASSEMBLY** Contains a specially designed liner and flexible drive shaft.
- 6. LOOP HANDLE** The loop (front) handle can be repositioned for comfortable operation by loosening the screws and moving the handle.
- 7. IGNITION SWITCH** "Slide Switch" mounted on top of the Throttle Trigger Housing. Move switch FORWARD to Run, BACK to STOP.
- 8. THROTTLE TRIGGER** Spring loaded to return to idle when released. When accelerating, press trigger gradually for best operating technique. Do NOT hold trigger while starting.
- 9. GRIP** Rear (right hand) handle.
- 10. PURGE BULB** Pushing purge bulb (7 to 10 times before starting), will remove all air and stale fuel from fuel system and bring fresh fuel to the carburetor.
- 11. STARTER HANDLE** pull handle until engine starts, then return handle slowly. DO NOT let handle snap back or damage to starter will occur.
- 12. FUEL TANK CAP** Covers and seals fuel tank.
- 13. AIR CLEANER COVER** contains replaceable felt element.
- 14. CHOKE** the choke control is located on the right side of the filter cover.
  - **COLD STARTS** Move lever up to close choke for cold starts. Push lever down for RUN position.
- 15. SPARK PLUG** Provides spark to ignite fuel mixture.
- 16. PLUG GUARD** Protects the spark plug from damage.
- 17. MUFFLER/SPARK ARRESTER** the spark arrester muffler controls the exhaust noise and prevents hot, glowing particles of carbon from leaving the muffler.
- 18. FUEL TANK** Contains fuel and fuel filter.



# DESCRIPTION SE-26

## STICK EDGER SE-26

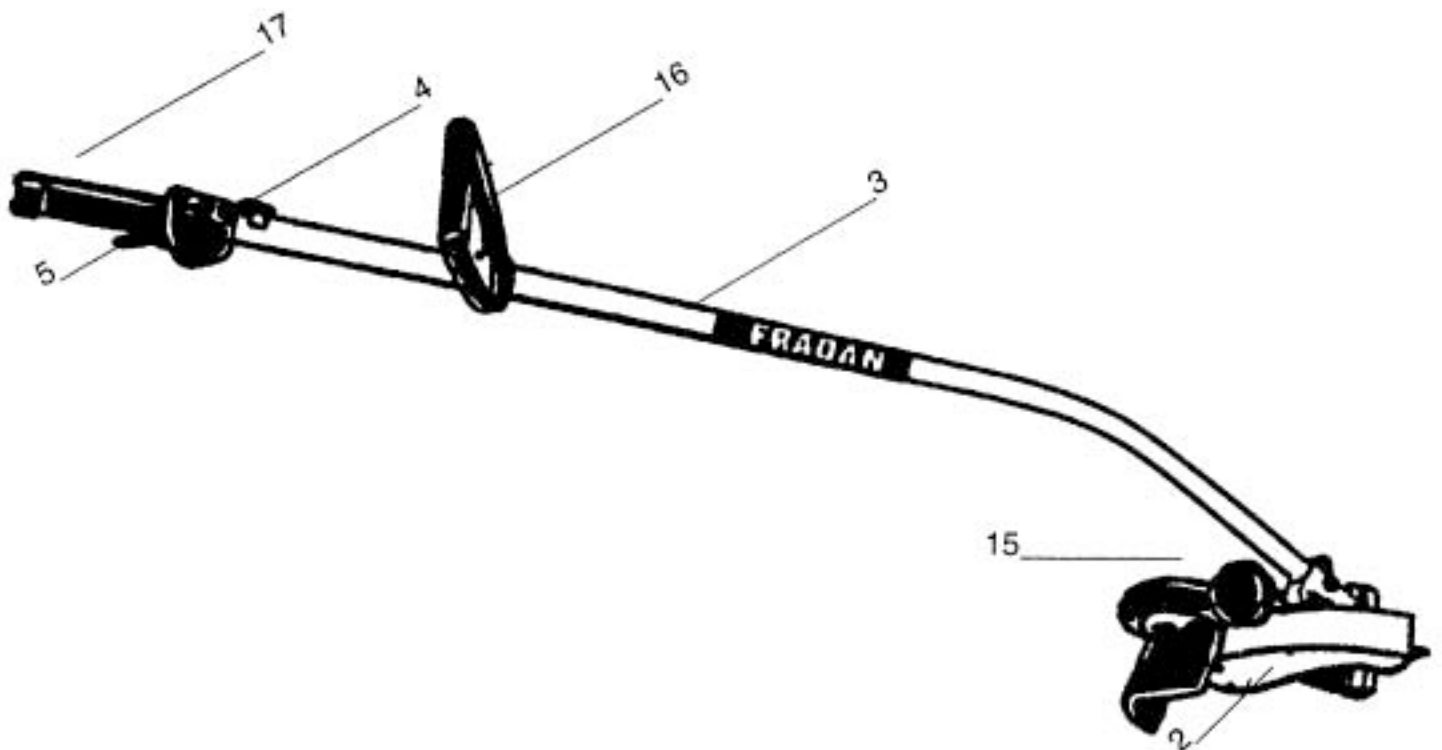
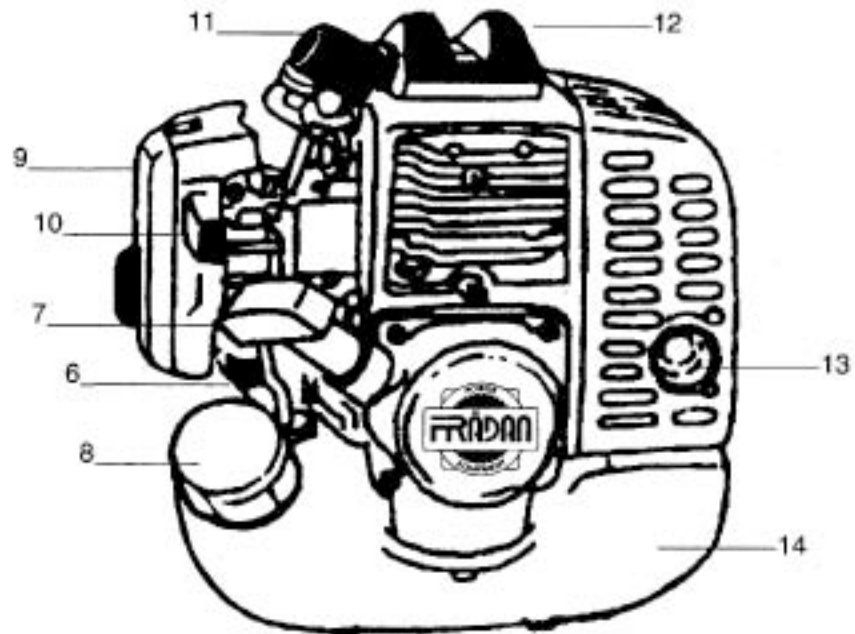



## DESCRIPTION SE-26

1. **SAFETY MANUAL** Included with unit. Read before operation and keep for future reference to learn proper, safe operating techniques.
2. **DEBRIS SHIELD** Mounted just above the cutting attachment. Helps protect operator by deflecting debris produced during the trimming operation. Do not operate unit without shield.
3. **DRIVE SHAFT ASSEMBLY** Contains a specially designed liner and flexible drive shaft.
4. **IGNITION SWITCH** "Slide Switch" mounted on top of the Throttle Trigger Housing. Move switch FORWARD to Run, BACK to STOP.
5. **THROTTLE TRIGGER** Spring loaded to return to idle when released. When accelerating, press trigger gradually for best operating technique. Do NOT hold trigger while starting.
6. **PURGE BULB** Pushing purge bulb (7 to 10 times before starting), will remove all air and stale fuel from fuel system and bring fresh fuel to the carburetor.
7. **STARTER HANDLE** pull handle until engine starts, then return handle slowly. DO NOT let handle snap back or damage to starter will occur.
8. **FUEL TANK CAP** Covers and seals fuel tank.
9. **AIR CLEANER** contains replaceable felt element.
10. **CHOKE** the choke control is located on the right side of the filter cover.
  - **COLD STARTS** Pull lever up to close choke for cold starts. Push lever down for RUN position.
11. **SPARK PLUG** Provides spark to ignite fuel mixture.
12. **PLUG GUARD** Protects the spark plug from damage.
13. **MUFFLER/SPARK ARRESTER** the spark arrester muffler controls the exhaust noise and prevents hot, glowing particles of carbon from leaving the muffler.
14. **FUEL TANK** Contains fuel and fuel filter.
15. **ADJUSTING KNOB** controls depth of cutting blade.  
**WARNING:** Always turn off engine and make sure engine has stopped before making any adjustments.
16. **LOOP HANDLE** The loop (front) handle can be repositioned for comfortable operation by loosening the screws and moving the handle.
17. **GRIP** Rear (right hand) handle.

## ASSEMBLY ST-26

### ADJUSTING LOOP HANDLE

Position handle in a comfortable operating position and tighten screws.

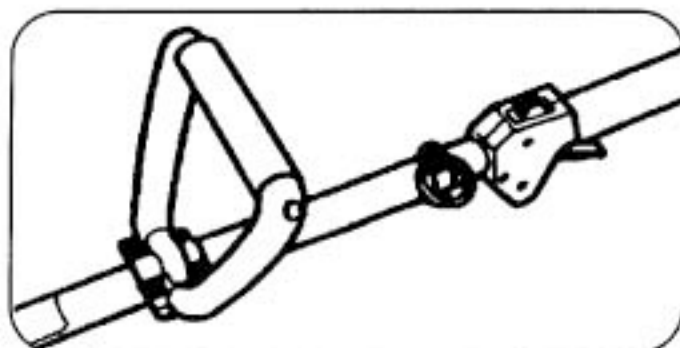

### INSTALLING PLASTIC SHIELD

(For Nylon Line Operation)

Fit the shield to the gear box housing.

Place 3" washer under plastic shield using 3 4x20mm screws and secure to gear housing.

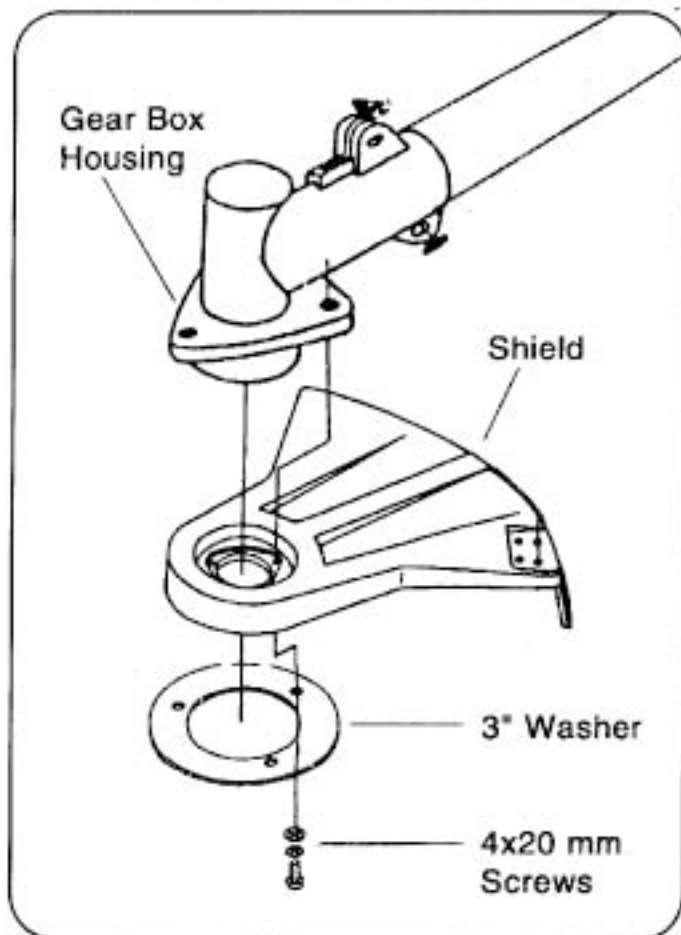

**WARNING**



**DANGER**

### INSTALLING NYLON LINE CUTTER HEAD

Align hole in adapter plate with hole in shaft and install locking tool.

Thread cutter head onto shaft (turning it counter clockwise) until it is tight.

Remove locking tool.

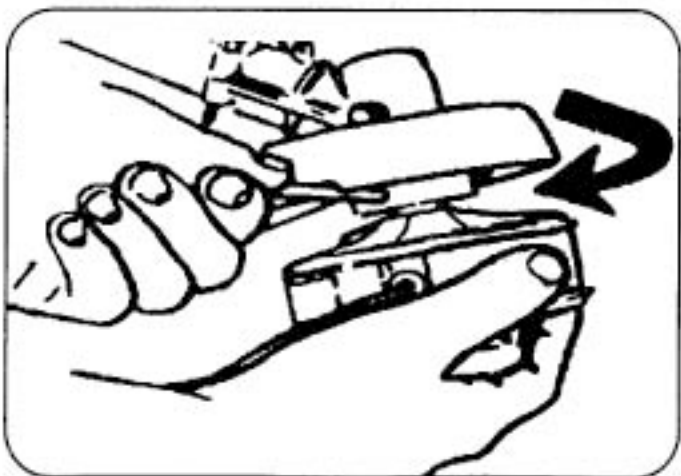

## ASSEMBLY SE-26

**WARNING**



**CAUTION**

### **EXCESSIVE VIBRATION - STOP ENGINE IMMEDIATELY**

Excessive vibration of blade means that it is not properly installed- stop engine immediately and check blade. Blade not properly installed will cause injury.

#### **GEAR BOX & GUARD ASSEMBLY**

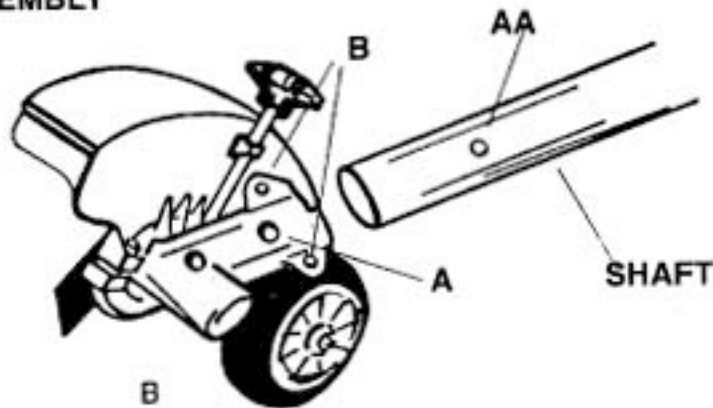

### **MODEL SE-26 GEAR BOX AND GUARD ASSEMBLY**

- Remove 4mm bolts A from gear box assembly.
- Loosen 2-4mm bolts B.
- Slide gear box onto shaft assembly hole AA.
- Align hole A with hole AA.
- Install bolt A into shaft assembly hole AA and tighten.
- This will ensure proper alignment.
- Tighten the 2-4mm bolts B.
- Secure METAL BLADE between upper and lower plates with Left Handed NUT. Make sure that Cotter PIN is installed.

#### **ADJUSTING HANDLE FOR SE-26**

Install handle onto shaft. Position handle in a comfortable operating position and tighten screws.

## RULES FOR SAFE OPERATION

### WARNING DANGER

All model trimmers and brushcutters can throw small stone, metal or small objects as well as the material being cut. Read these "Rules for Safe Operation" with care. Follow the instructions in your operator's manual.

Do not allow anyone to enter the operating **DANGER ZONE** with you. The danger zone is an area 15 meters in radius (about 16 paces) or 50 feet.

Insist that persons in the **RISK ZONE** beyond the danger zone wear eye protection from thrown objects. If the unit must be used where there are unprotected people, operate at a low throttle speed to reduce the risk of thrown objects.

Read the operator's manual carefully. Be thoroughly familiar with the controls and proper use of the unit. Know how to stop the unit and shut off the engine. Know how to unhook a harnessed unit quickly.

Never allow anyone to use the unit without proper instruction. Be sure the operator wears the foot, leg, eye, face and hearing protection.

Do not rely on the debris shield on the unit to protect your eyes from ricocheting or thrown objects. Keep the area clear of bystanders, children and pets. Never allow children to operate or play with the unit.

### WARNING DANGER

In addition to head, eye, face and ear protectors, shoes to protect your feet improve your footing on slippery surfaces. Do not wear ties, jewelry, or loose, dangling clothing which could be caught in the unit. Do not wear open-toed footwear, or go barefoot or bare legged. In certain situations you must wear total face and head protection.

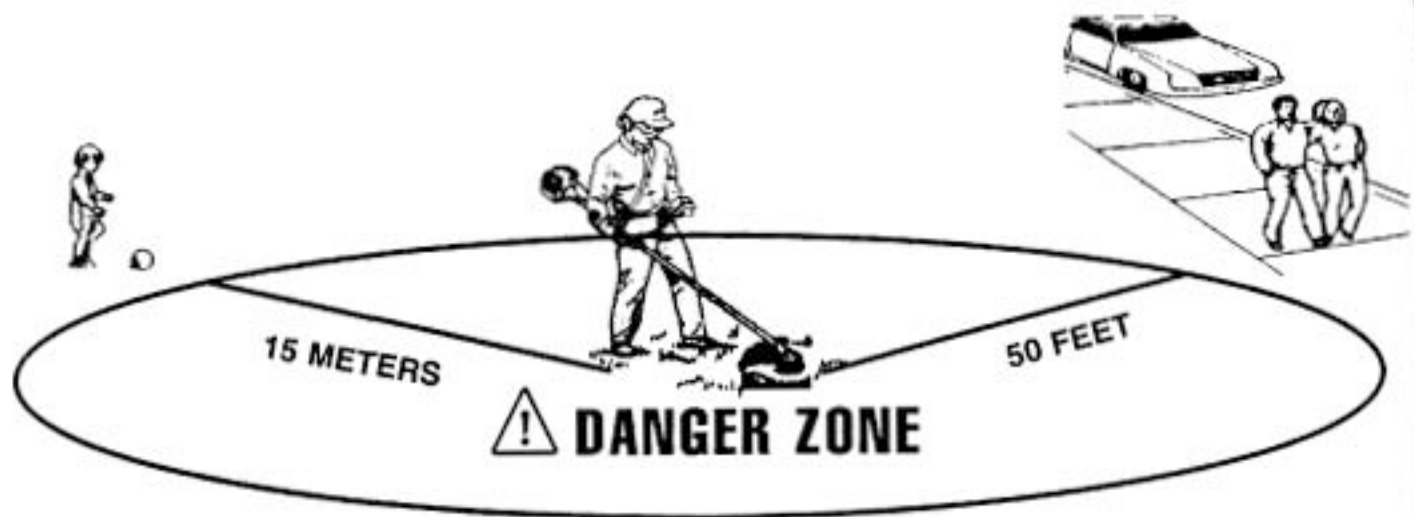

NO PERSON EXCEPT OPERATOR ALLOWED 15 METERS RADIUS DANGER ZONE. EYE, EAR, FACE, FOOT, LEG AND BODY PROTECTION MUST BE WORN BY OPERATOR. PERSONS IN DANGER ZONE OR RISK BEYOND DANGER ZONE SHOULD WEAR EYE PROTECTION AGAINST THROWN OBJECTS. RISK DIMINISHES WITH DISTANCE FROM DANGER ZONE.



## CUTTING WITH A NYLON HEAD

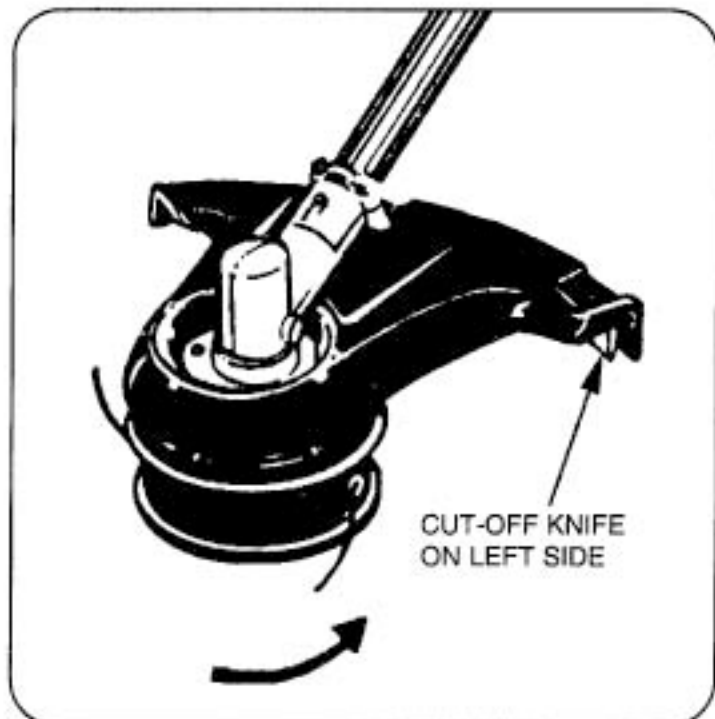

Line head rotates in a **COUNTER-CLOCK-WISE** direction. The **CUT-OFF KNIFE** will be on the left side of the debris shield.

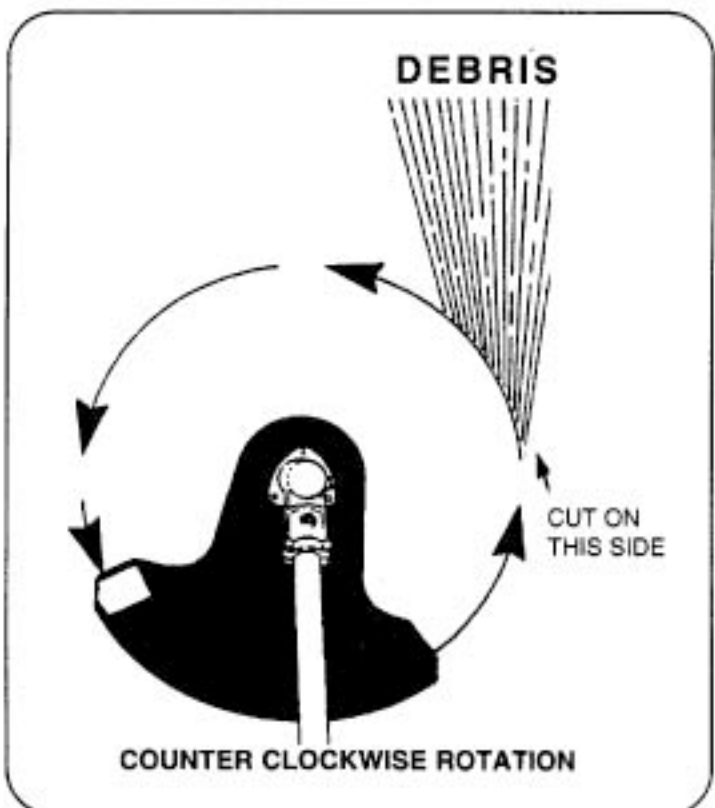

### WARNING DANGER

The proper debris shield must be in place on the unit when nylon cutting line is used. The cutting line can flap around if too much line is exposed. Always use the plastic debris shield with cut-off knife when using nylon cutting heads.

For nearly all cutting, it is good to tilt the line head so that contact is made on the part of the line circle where the line is moving **AWAY** from you and the debris shield. (See appropriate picture) This results in the debris being thrown **AWAY** from you.

### WARNING DANGER

Tilting the head to the wrong side will shoot the debris **TOWARDS** you. If the line head is held flat to the ground so that cutting occurs on the whole line circle, debris will be **THROWN** at you, drag will slow the engine down, and you will use up a lot of line.

### WARNING DANGER

Use only quality nylon monofilament line of the diameter .060 to .125. Never use wire or wire-reinforced line in place of nylon trimmer line. Load your nylon line cutting head only with nylon trimmer line of the proper diameter.

### WARNING DANGER

Use extreme caution when operating over bare spots and gravel, because the line can throw small rock particles at high speeds. Debris shields on the unit cannot stop objects which bounce or ricochet off hard surfaces.



## CUTTING WITH A NYLON HEAD

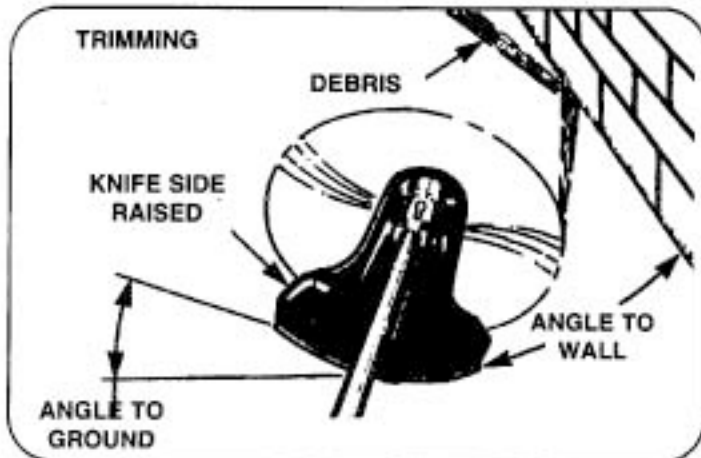

### TRIMMING

This is feeding the trimmer carefully into the material you wish to cut. Tilt the head slowly to direct debris away from you. If cutting up to a barrier such as a fence, wall or tree, approach from an angle where any debris ricocheting off the barrier will fly away from you. Move the line head slowly until the grass is cut right up the barrier, but do not jam (overfeed) the line into the barrier. If trimming up to a wire mesh or chain linked fence be careful to feed only up to the wire. If you go too far the line will snap off around the wire. Trimming can be done to cut through weed stems one at a time. Place the trimmer line head near the bottom of the weed—never high up which could cause the weed to chatter and catch the line. Rather than cut the weed right through, just use the very end of the line to wear through the stem slowly.

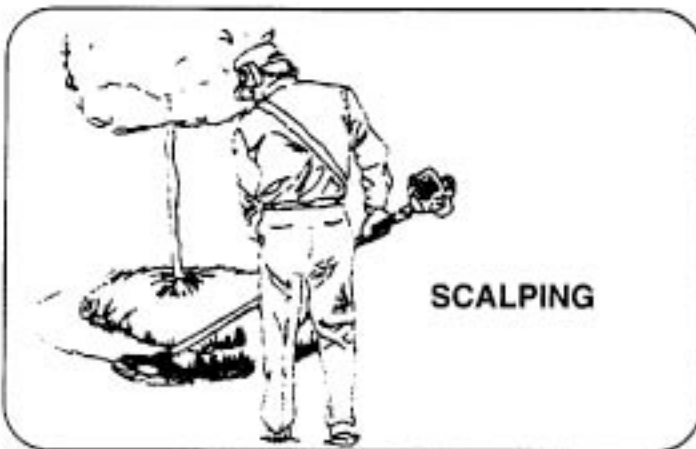

### WARNING DANGER

Do not use a steel blade for edging or scalping

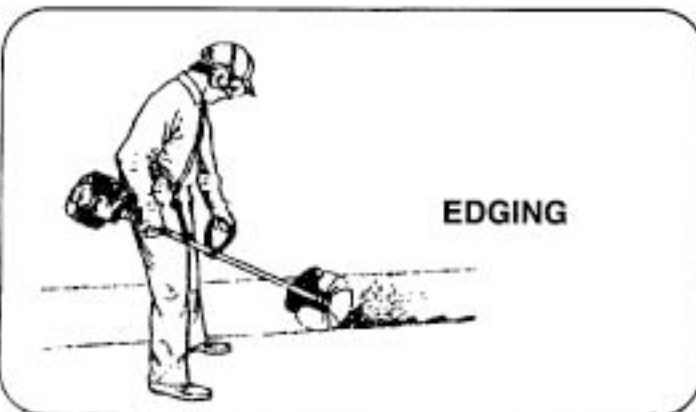

### SCALPING and EDGING:

Both of these are done with the line head tilted at a steep angle. Scalping is removing top growth leaving the earth bare. Edging is trimming the grass back where it has spread over a sidewalk or driveway. During both edging and scalping, hold the unit at a steep angle and in position where the debris and any dislodging dirt and stones will not come back towards you even if it ricochets off the hard surface. Although the picture shows how to edge and scalp every operator must find for himself the angles which suit his body size and cutting situation.

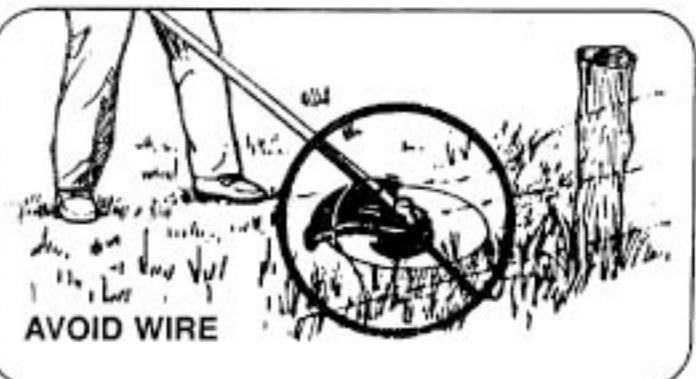

### WARNING DANGER

Do not trim in any area where there are strands of fencing wire. Wear protective safety protection. Do not cut where you cannot see what the cutting device is cutting.

## FUEL & OIL MIXTURE



**WARNING**

- Never fill the fuel tank to the very top.
- Never add fuel to the tank in a closed non-ventilated area.
- Do not add fuel to this unit close to an open fire or sparks.
- Be sure to wipe off spilled fuel before attempting to start engine.
- Do not attempt to refuel a hot engine.

Fuel used for this model is a mixture of unleaded gasoline and approved engine lubricant. When mixing gasoline with a **FRADAN** approved two-cycle engine oil, use only gasoline which contains **NO ETHANOL** or **METHANOL** (Types of Alcohol) Use branded 89 octane or higher unleaded gasoline known to be of good quality. This will help to avoid possible damage to engine fuel lines and other engine parts.

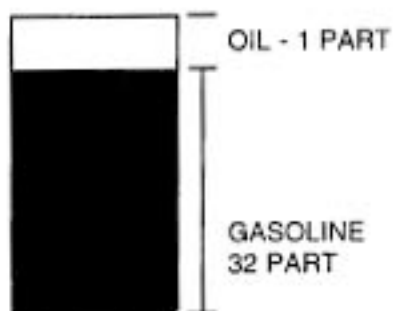

### MIXTURE RATIO IS 32:1

**GASOLINE - 32 part      OIL-1 part**

Fuel mixture at the rate other than 32:1 may cause damage to the engine. Ensure mixture ratio is correct.

### FUEL MIX CHART 32-1

GAS	OIL	GAS	OIL
GAL.	FL. OZ.	LITERS	ML
1	4	4	125
2	8	8	250
4	16	20	625

#### FUEL

The engine uses two-stroke fuel, a mixture of gasoline and specially blended **FRADAN** brand 2-stroke lubricant 32:1

#### GASOLINE

Use branded 89 octane or higher unleaded gasoline known to be of good quality.

#### MIXING FUEL

Follow directions on fuel mixing chart above.

#### STORING FUEL

Store fuel only in a clean, safe, approved container. Check and follow local ordinances on type and location of storage container.

#### IMPORTANT

Two-stroke fuel may separate. Shake fuel container thoroughly before each use.

Stored fuel ages. Do not mix more fuel than you expect to use within a month.



## PREPARING FOR OPERATIONS

### FUEL AND OIL MIXTURE

Inspect fuel tank making sure that it is clean and fill with fresh fuel. Use a mixture of 32-1. (See Fuel and Oil Mixture on page 16)

WHEN MIXING GASOLINE WITH TWO CYCLE ENGINE OIL, USE ONLY GASOLINE WHICH CONTAINS NO ETHANOL OR METHANOL (TYPES OF ALCOHOL). THIS WILL HELP TO AVOID POSSIBLE DAMAGE TO ENGINE FUEL LINES AND OTHER ENGINE PARTS.  
DO NOT MIX GASOLINE AND OIL DIRECTLY IN THE ENGINE FUEL TANK.

**IMPORTANT:** Failure to follow proper fuel mix instructions may cause damage to the engine.

1. When preparing fuel mixture, mix only the amount needed for the job you are to do. Do not use fuel that has been stored longer than two months. Fuel mixture stored longer than this will cause hard starting and poor performance. If fuel mix has been stored longer than this time, it should be removed and filled with a fresh mixture.

**WARNING**



**DANGER**

1. Never fill the fuel tank to the very top.
2. Never add fuel to the tank in a closed non-ventilated area
3. Do not add fuel to this unit close to an open fire or sparks.
4. Be sure to wipe off spilled fuel before attempting to start engine.
5. Do not attempt to refuel a hot engine.
6. Always make sure fuel cap is properly installed to prevent spillage of fuel.

### CHECK POINTS BEFORE OPERATION

1. Check for loose bolts, nuts and fittings.
2. Check the air cleaner for dirt. Clean the air filter of all dirt, etc. before operation.
3. Check to be sure that protector is securely in place.
4. Check to be sure fuel cap is properly installed.

**WARNING**



**DANGER**

The engine exhaust from this product contains chemicals known to the State of California to cause cancer, birth defects, or other reproductive harm.

# OPERATIONS



## ENGINE STARTING AND STOPPING PROCEDURES

### STARTING COLD ENGINE

1. Move the stop switch to "START" position.
2. Give a gentle push on the primer pump repeatedly (7-10 times) until fuel comes into the primer pump.
3. **Cold Starts:** move lever up to close choke.
4. Pull starter handle until engine false fires.
5. Move choke lever downward (excessive cranking with choke lever will cause flooding of engine making it difficult to start.)
6. Pull starter handle until engine starts.
7. Allow engine to warm up for a few minutes before using.

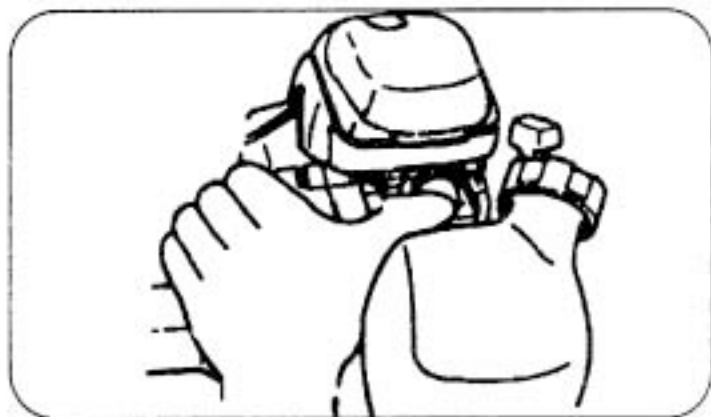
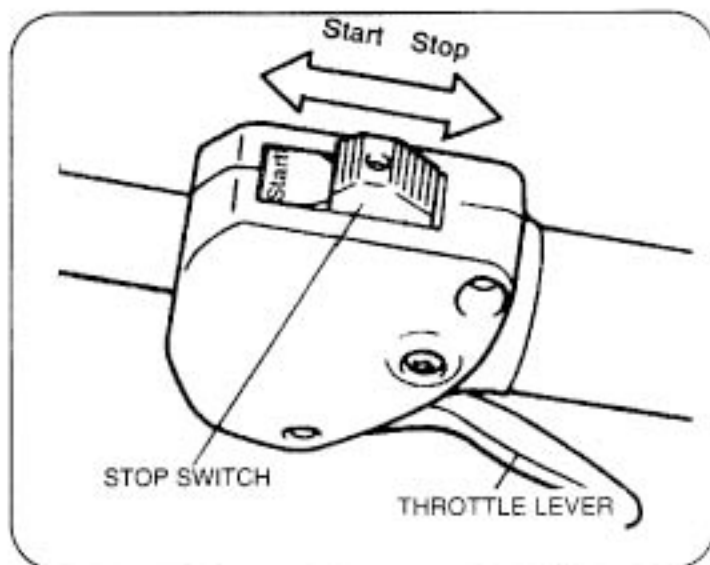

### START WARM ENGINE

- If fuel tank was not run dry, pull starter one to three times and engine should start. **DO NOT USE CHOKE**
- If fuel tank was run dry, after refilling repeat steps 3 thru 7 in STARTING COLD ENGINE

### STOPPING THE ENGINE

- Move switch to STOP position.

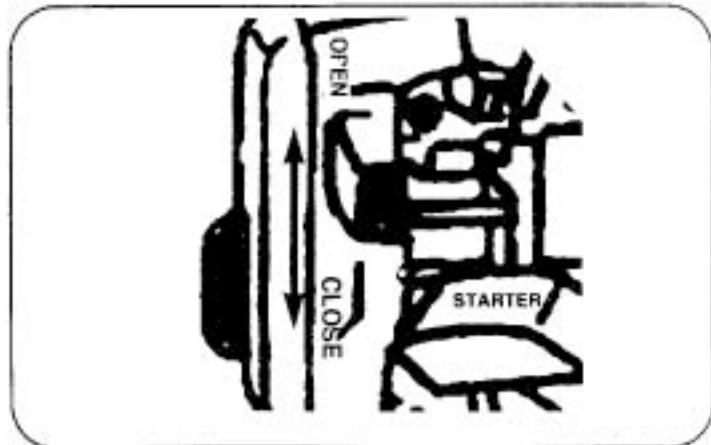

## MAINTENANCE & CARE

### AIR FILTER

- Accumulated dust in the air filter will reduce engine efficiency, increase fuel consumption and allow abrasive particles to pass into the engine. Remove the air filter as often as necessary to maintain in a clean condition.
- Light surface dust can readily be removed by tapping the filter. Heavy deposits should be washed out in suitable solvent.
- Remove filter cover by loosening air filter cover knob.

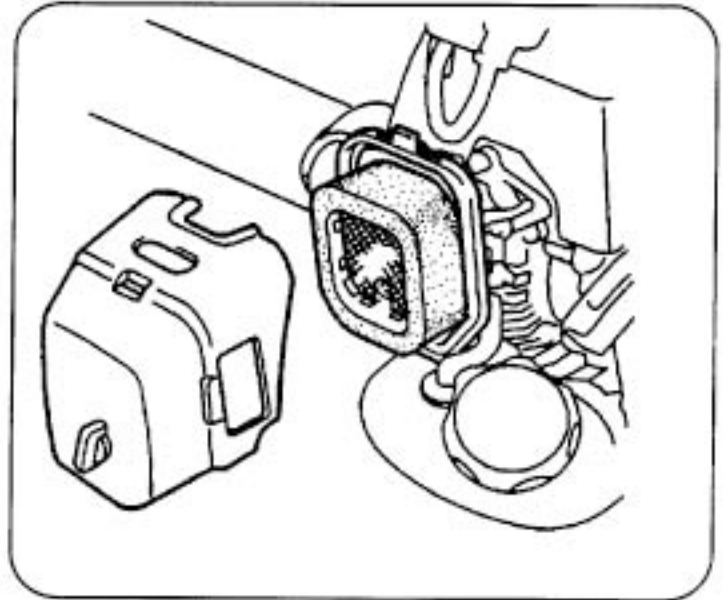

### ADJUSTING CARBURETOR

#### NOTE

Do not adjust carburetor unless necessary. If you have trouble with the carburetor, see your dealer. Improper adjustment may cause engine damage and void warranty.

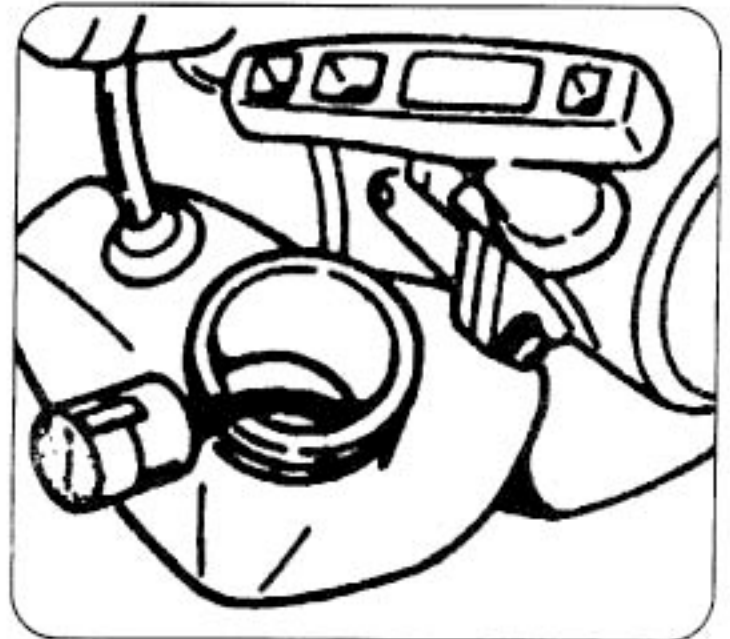

### FUEL FILTER

- Fuel tank is fitted with a fuel filter. Filter is situated at the free end of fuel line and can be picked out through fuel port with a piece of hooked wire or the like.
- Check the fuel filter periodically. Do not allow dust to enter into fuel tank. Clogged filter will cause difficulty in starting engine or abnormalities in engine performance.
- When filter is dirty, replace the filter.
- When the inside of the fuel tank is dirty, it can be cleaned by rinsing the tank out with gasoline.

### CHECK SPARK PLUG

- Do not attempt to remove the plug from a hot engine in order to avoid possible damage to the threads.
- Clean or replace the plug if fouled with heavy oily deposits.
- Replace the plug if the center electrode is worn or rounded at the end.
- Spark gap 0.6-0.7 mm (.023" .028")
- Fastening torque=145-155kg.cm (125-135in.lb)

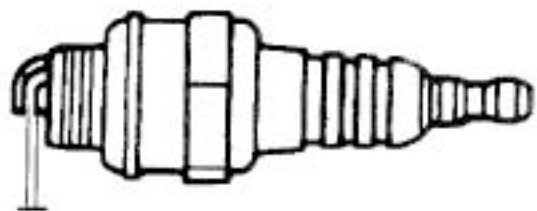

(0.6-0.7 MM(0.023" 0.028" IN.)



## TROUBLE SHOOTING

**FAILURES** such as difficulty in starting engine, irregularity in functions and abnormality in performance can normally be prevented if careful attention is paid to all operating instructions and maintenance procedures.

**Should the engine not function properly, check the following:**

- That the fuel system is in good condition and fuel is flowing to the engine.
- The ignition system is in good condition and the spark plug, sparks correctly.
- Compression of the engine is adequate.

### FAILURE TO START

- Dispose of fuel in tank.
- Insure that fuel is fresh and clean.
- Check fuel filter to make sure it is clean. (Replace filter if necessary)
- Make sure air filter elements are clean.
- Install new, properly gapped spark plug.
- When there is serious trouble with the unit, **do not try to repair it yourself**, but have your **FRADAN** distributor or dealer do it for you.

### EXTENDED STORAGE

- Inspect, clean and repair unit if necessary.
- Remove all fuel from tank.
- Start engine - This will consume all fuel in fuel line and carburetor.
- Remove spark plug and pour one tea spoon of clean motor oil into spark plug hole of cylinder - replace spark plug.
- Store in clean, dry, dust free area.



## FRADAN LIMITED WARRANTY POLICY

Effective April 30, 2000 • Replaces all undated Warranties and all Warranties dated before January 1, 1999

This limited warranty is extended by FRADAN MANUFACTURING CORP. to the first retail purchaser only and is not transferable to subsequent owners. For 90 days from the date of purchase FRADAN Manufacturing will repair any defect in material or workmanship at no charge. From the 91st day until one year from the date of purchase, FRADAN will furnish replacement parts for any defective parts, free of charge. You pay for labor. The responsibility of FRADAN MANUFACTURING CORP., under this warranty is limited to replacement or repair of any defective part by an authorized FRADAN dealer subject to approval by FRADAN MANUFACTURING CORP. This warranty does not include or cover damage to the complete product caused by:

- Lack of lubrication or engine failure due to improper oil fuel ratio.
- Parts not warranted are normal maintenance items such as spark plugs, air and fuel filters, hoses, blowing tubes, starter rope, vibration isolators, throttle cable, all cutting attachments, lubricants, engine tune-ups, and sparks arrestor screen.
- Alterations or modifications including aftermarket parts not authorized by FRADAN MANUFACTURING CORP.
- Damage caused by the use of gasoline containing methy (wood) alcohol or gasoline containing less than 89 octane. Only use gasoline which contains 89 octane or higher. Gasohol which contains a maximum 10% ethyl (grain ) alcohol or 15% MTBE (methyl tertiary-butyl ether) is also approved. The prescribed mixing ratio of gasoline to oil is listed in the FRADAN owner's manual.
- Defects, malfunctions, or failures resulting from abuse, misuse, neglect, modifications, alterations, improper servicing, improper storage, use of unauthorized attachments, replacement parts including failure to provide or perform required maintenance services as prescribed in the owners manual.
- Preventive maintenance is the warranty holder's responsibility.
- Damages caused by tampering with engine speed governors, or running engines above specified and recommended engine speed.
- Engine damage caused by the use of other or any starting fluids.
- Damages caused by dirt, salt water corrosion, rust, varnish, and moisture.
- Operation of the unit with improperly serviced, damaged, or removed air filter.
- Failure to follow the setup, predelivery service, and adjustment outlined in operator's manual.
- Damage caused by the pressure of steam cleaning the product.

Parts replaced or repaired under this warranty are warranted only for the balance of the warranty period. All defective parts replaced under warranty become the property of FRADAN MANUFACTURING CORP. For warranty repairs, you must at your own expense, arrange to deliver the shipment (and return after repairs are completed) of your FRADAN unit to FRADAN MANUFACTURING CORP. or an authorized FRADAN servicing dealer. Under no circumstances is FRADAN responsible for extra expenses including shipping and handling, travel, payment for lost time or pay and for any inconvenience and storage. To locate your nearest authorized FRADAN servicing dealer call (914) 632-3769.

**THIS LIMITED WARRANTY IS IN LIEU OF ALL OTHER EXPRESS WARRANTIES. ANY IMPLIED WARRANTY OF FITNESS FOR A PARTICULAR PURPOSE, MERCHANTABILITY OR OTHERWISE APPLICABLE TO THIS PRODUCT, SHALL BE LIMITED IN DURATION TO THE DURATION OF THIS LIMITED WARRANTY. FRADAN CORP. SHALL NOT BE LIABLE FOR ANY SPECIAL INCIDENTAL OR CONSEQUENTIAL DAMAGES.**

To validate this warranty. Complete and return within ten (10) days of the date of purchase the warranty registration card supplied with your FRADAN product. Your receipt of purchase should be maintained and presented to an authorized FRADAN servicing dealer for warranty service.

**SOME STATES DO NOT ALLOW LIMITATIONS ON HOW LONG AN IMPLIED WARRANTY LASTS. THIS WARRANTY GIVES YOU SPECIFIC LEGAL RIGHTS, AND YOU MAY ALSO HAVE OTHER LEGAL RIGHTS WHICH VARY FROM STATE TO STATE.**

### **FRADAN MANUFACTURING CORP.**

Manufacturers of Power Equipment

499 Fifth Avenue, New Rochelle N.Y. 10801 • Phone (914) 632-3769 • Fax (914) 632-1652