



OPERATOR MANUAL

Fradan Truck Loader Tow Behind

31 HP Tow Behind Model = TLV-31D

31 HP Skid Mount = LV-31D

40 HP Tow Behind Model = TLV-40LD

40 HP Skid Mount Model = LV-40LD

35 HP Tow Behind Model = TLV-35D

35 HP Skid Mount = LV-35D



Warning  Danger

Read instructions carefully and follow rules for safe operation.
Failure to do so could result in serious injury.

WELCOME TO THE FRADAN FAMILY



Congratulations! You are now the owner of a quality **FRADAN TRUCK LOADER**.

Fradan manufactures a family of high performance, reliable power equipment. Our designs are based on years of personal use of landscape equipment.

We at Fradan have revolutionized the landscaping industry, offering modern, reliable, high performance equipment designed to meet today's environmental demands and exceed tomorrow's.

FRADAN built means durability, quality, maximum performance and non-obsolescence. With proper care and maintenance of your unit, we assure you years of service-free operation. This booklet refers to the information which you should learn in order to take advantage of its outstanding performance.

Contents

- Introduction** 3
- Technical Data** 3
- Graphic Warnings** 4
- Safety Rules and Precautions** 4
- Fuel & Oil** 6
- Engine** 6
- Preparing For Operations** 7
- Check points before Operation** 7
- Operating Instructions** 8
- Transportation** 10
- Maintenance Instructions** 12
- Storage** 13
- Trouble shooting** 13

Specifications, descriptions and illustrative material in this manual are as accurate as known at the time of publication, but are subject to change without notice. Illustrations may include optional equipment and accesaccessories, and may not include all standard equipment.

INTRODUCTION

The **FRADAN LEAF VACUUM** model is a ruggedly built, high performance gasoline powered unit specially designed for vacuuming leaves and debris. Proper maintenance and use of the Fradan Leaf Vacuum will guarantee years of safe, service-free, reliable operation.

We wish for you to gain sufficient knowledge from this booklet before operating your Fradan, and make the best use of it in the future. We urge you to follow these instructions to assure safe and reliable operation.

Technical Data



Model	TLV-31D	LV-31D	TLV-35D	LV-35D	TLV-40LD
Engine	31 HP Vanguard Engine	31 HP Vanguard Engine	35 HP Vanguard Engine	35 HP Vanguard Engine	40 HP Lombardini Diesel Engine
Engine Displacement	896cc	896cc	993cc	993cc	1649cc
Starter	Turn Key Electric Start	Turn Key Electric Start	Turn Key Electric Start	Turn Key Electric Start	Turn Key Electric Start
Fuel Capacity	5.5 gal	5.5 gal	8.5 gal	8.5gal	8.5 gal
Tire Size	ST 205-75 R15 6ply	N/A	ST 205-75 R15 6ply	N/A	ST 205-75 R15 6 ply
Lighting Kit	Heavy Duty LED Type	N/A	Heavy Duty LED Type	N/A	Heavy Duty LED Type
Vacuum Hose	14in. diameter by 10ft. long	14in. diameter by 10ft. long	16in. diameter by 10ft. long	16in. diameter by 10ft. long	16in. diameter by 10ft. long
Impeller	Reinforced 4 blades 5/16 inch steel	Reinforced 4 blades 5/16 inch steel	Reinforced 4 blades 1/2 inch steel	Reinforced 4 blades 1/2inch Steel	Reinforced 4 blades 1/2inch Steel
Tow Bar	Standard Pintel * optional 2 5/16 ball hitch	N/A	Standard Pintel * optional 2 5/16 ball hitch	N/A	Standard Pintel * optional 2 5/16 ball hitch
Hitch Height	Adjustable (15– 24 inch)	N/A	Adjustable (15– 24 inch)	N/A	Adjustable (15– 24 inch)
Discharge Hose	8in x 5ft Heavy duty flexible metal	8in x 5ft Heavy duty flexible metal	12in x 5ft Heavy duty flexible metal	12in x 5ft Heavy duty flexible metal	12in x5ft Heavy duty flexible metal
Hitch Class requirement	Class III	N/A	Class III	N/A	Class III
Wheel Base	57 inch	N/A	76 inch	N/A	76 inch
Suspension	Rubber Torsion Bar Suspension	N/A	Rubber Torsion Bar Suspension	N/A	Rubber Torsion Bar Suspension
Dimension	81 x 58 x 130 inch	65 x 36 x 99 inch	124 x 76 x 133 inch	74 x 54 x 101 inch	124 x 76 x 133 inch
Dry Weight	1042 lbs	736 lbs	1980 lbs	1550 lbs	2240 lbs

*All Specifications are subject to change without notice

GRAPHIC WARNINGS

Because a Truck Loader uses gasoline and draws/blows air and debris in at a high speed, safety precautions must be observed to reduce the risk of personal injury. Read this manual carefully. Be familiar with the controls and the proper use of the machine.

 Stay Alert!! This graphic accompanied by the words **WARNING** and **DANGER** calls attention to an act or condition which can lead to serious injury when you see this symbol, Heed its Warning!

  Read & understand operator's manual and safety manual.

 Always wear eye and ear protection.

 Keep hand & feet away from air discharge areas. Rotating fan blades will cause serious injury.

 Safety Rules and Precaution. Read and fully understand.



SAFETY RULES & PRECAUTIONS

 **IN THE INTEREST OF SAFETY.....BEFORE STARTING ENGINE, READ AND UNDERSTAND THE ENTIRE OPERATOR'S MANUAL & ENGINE MANUAL** 

Proper Safety precautions must be observed. Like all power equipment this unit must be handled carefully.

Warning  Danger. To reduce the potential for accidents, comply with the safety instructions in this manual. Failure to comply may result in serious personal injury and/ or equipment and property damage.

DO NOT EXPOSE YOURSELF OR OTHERS TO DANGER. Follow these general rules. Do not permit others to use this machine unless they are thoroughly responsible and have read, and understand the operator's manual and are trained in its operation.

General Safety Rules and Precautions to Observe

- Always wear safety goggles for eye protection.
- Dress properly; do not wear loose clothing, scarves or jewelry that could become caught in moving parts of the unit. Safe, sturdy, nonskid foot wear should always be worn. Long hair should be tied back.
- Never wear loose clothing near intake hose.
- Always wear gloves to protect your hands.
- Always wear ear protectors when operating machine.
- Do not remove any shields, guards or decals. If a shield, guard or decal is damaged or does not function, repair or replace it before operating the vacuum
- DO NOT USE** any attachment with this Leaf Vacuum other than the ones recommended by FRADAN. Serious injury to the operator or bystanders could result as well as damage to the machine.
- Do not use the unit if it is damaged or poorly adjusted.
- Do not use this unit for any job other than those for which it is intended as described in this manual.
- Onlookers should be kept at a safe distance from the work area, at least 100 feet/30 meters.
-  **WARNING- KEEP CHILDREN, PETS, AND BYSTANDERS AWAY-** Do not permit children to contact vacuum. Keep children a safe distance from work area.
- When ever approaching an operator of the machine, carefully call his attention and confirm that the operator stops the engine. Be careful not to startle or distract the operator which can cause an unsafe situation.
- Never allow a person mentally ill, under influence of alcoholic drinks or drugs or too young in age, to operate the blower.



SAFETY RULES & PRECAUTIONS



IN THE INTEREST OF SAFETY.....BEFORE STARTING ENGINE, READ AND UNDERSTAND THE ENTIRE OPERATOR'S MANUAL & ENGINE MANUAL





- ☑ Do not use the unit when you are tired or under the influence of medication, drugs or alcohol. Never leave the machine unattended while in operation. Make sure that the driver of the towing vehicle has the operator of the unit in full view at all times.
- ☑ Never allow a person to ride, sit or stand on the unit or towing vehicle other than in the driver's cab of the towing vehicle.
- ☑ When operating the truck loader, operator must stay to the side of the machine, never in front or behind.
- ☑ Always keep a safe distance between two or more operators when working together simultaneously.
- ☑ Beware that the machine is loud and during normal operation it may interfere with speech communication.
- ☑ Pay special attention to operation in the rain or just after the rain as the ground may be slippery.
- ☑ DO NOT POINT THE VACUUM OULET in the direction of people, cars, glass, or other similar items which could be injured or damaged by blown debris.
- ☑ Do not operate during excessive vibration.
- ☑ Never allow a person to ride, sit or stand on the unit or towing vehicle other than in the driver's cab of the towing vehicle.
- ☑ When operating the truck loader, operator must stay to the side of the machine, never in front or behind.
- ☑ Always keep a safe distance between two or more operators when working together simultaneously.
- ☑ Beware that the machine is loud and during normal operation it may interfere with speech communication.
- ☑ Pay special attention to operation in the rain or just after the rain as the ground may be slippery.
- ☑ DO NOT POINT THE BLOWER OULET in the direction of people, cars, glass, or other similar items which could be injured or damaged by blown debris.
- ☑ Do not operate during excessive vibration.
- ☑ Do not park machine on a steep grade or slope, the machine can roll away uncontrollably causing injury or damage.
- ☑ Keep the machine away from fire or spark.
- ☑ Never tamper with governor springs, governor links or other parts which may change the governed engine speed.
- ☑ Never leave the engine running while the vacuum is unattended.
- ☑ Never transport the vacuum while the engine is still running.
- ☑ Check mounting hardware daily! Beware of the possibility that the machine may overturn, fall, or tip over because of unexpected movement of the vehicle
- ☑ When starting machine and it is NOT attached to your truck, the back leg brace must be in the down position and the pins locked in place. If legs are not in down locked position and engine is brought up to operating speed, the machine will flip over.
- ☑ Never look into discharge hose.
- ☑ Keep hands away from hose inlet and discharge chute.
- ☑ Never operate unit without suction hose attached properly.
- ☑ Discharge chute should always be aimed into a closed well ventilated box.
- ☑ Never start or operate machine without intake hose clamped onto machine.

• Safety Rules and Precaution for Impeller •

- ☑ **Warning Danger-** Turning off engine does not immediately stop impeller from rotating.
- ☑ **Warning Danger-** Never try to remove debris from the intake or discharge tube when engine is running or impeller is rotating.
- ☑ **Warning Danger-** Frozen leaves and rocks must never be vacuumed.
- ☑ **Warning Danger-** If excessive vibration occurs, turn off engine, disconnect spark plug and check for lodged foreign object, damaged impeller and loose impeller bolt or key.

Warning  **Danger.** The engine exhaust from this product contains chemicals known to the State of California to cause cancer, birth defects, or other reproductive harm.

 **Warning**  **Danger.** If the vacuum is used improperly or safety precautions are not followed the user risks serious injury to themselves and others. Read and understand the following before attempting to operate this vacuum.

FUEL & OIL



- Do not attempt to refuel a hot engine.
- Never fill the fuel tank to the very top.
- Never add fuel to the tank in a closed non - ventilated area.
- Do not add fuel to this unit close to an open fire or sparks.
- Be sure to wipe off spilled fuel before attempting to start engine.



All **FRADAN** Truck Loaders are shipped
WITHOUT OIL

When filling oil, refer to engine manufacturers' instruction manual.

Oil Type:

Engine: Refer to engine owners manual



General Safety Rules and Precautions to observe for fuel

- ✓ Do not fuel machine in an enclosed room or near open flames. Assure adequate ventilation. Outdoor refueling is recommended.
- ✓ Always store the fuel in a properly marked container that is approved by local codes and ordinances for such usage.
- ✓ Do not store in a closed area where fuel vapors can reach an open flame from hot water heaters, furnaces, etc. Store in a locked, well ventilated area only.
- ✓  **When refueling, be sure to stop the engine and confirm that it is cooled down. Never refuel when the engine is running. When gasoline spills, be sure to wipe it up completely dispose of those materials before starting the engine.**
- ✓ Do not smoke while handling fuel or filling tank.
- ✓ Fuel should always be stored in an approved, clearly marked container.

ENGINE



See your engine manual for proper
engine prep and operation.



Safety Rules and Precautions pertaining to Engine

- ✓ Never remove the tank cap while the engine is running.
- ✓ Never start or run the engine inside a closed room or building. Fumes from the exhaust contain dangerous carbon monoxide.
- ✓ Never attempt to make engine adjustments while the unit is running. Always make engine adjustments with the unit resting on a flat, clear surface.
- ✓ In start-up or during operation of the engine, never touch hot parts such as the muffler, the high voltage wire or the spark plug.
- ✓ After the engine has stopped, the muffler is still hot. Never place the machine in any place where there are flammable materials (dry grass, etc.), combustible gases or combustible liquids.
- ✓ Do not choke carburetor to stop engine. To properly stop the engine, gradually reduce engine speed to an idle, allow two minutes for the engine to cool down and then use appropriate switch to stop the engine.
- ✓ Never tamper with the engine speed selected by the engine manufacturer.

- ☑ Do not operate engine without a muffler. Inspect periodically and replace, if necessary.
- ☑ Do not operate engine with an accumulation of grass, leaves, dirt or other combustible material in the muffler area.
- ☑ Never run engine at excessive speeds. This may result in injury and/ or damage to unit.
- ☑ Do not use this engine on any forest covered, brush covered, or grass covered unimproved land unless a spark arrester is installed on the muffler. The arrester must be maintained in effective working order by the operator. In the state of California the above is required by law (section 4442 of the California Public Resources Code). Other states may have similar laws. Federal laws apply on federal lands.
- ☑ Do not run engine without air cleaner or air cleaner cover.

PREPARING FOR OPERATIONS



Be Sure Truck Loader Is Fully Assembled!

Never operate Loader without all guards and deflectors in place. Ensure that all nuts, bolts, screws are installed and properly tightened.



Handle fuel with care. It is highly flammable. Fueling a hot engine or fueling an engine near an ignition source can cause fire and result in serious personal injury and / or property damage.



- Inspect the entire machine for loose parts (nuts, bolts, screws, etc.) and any damage. Repair or replace as necessary before using the machine.
- Clean the machine completely, especially, the fuel tank, its surrounding, and the air cleaner.
- When preparing fuel, use only the amount needed for the job you are to do. Do not use fuel that has been stored longer than two months. Fuel stored longer than this will cause hard starting and poor performance. If fuel has been stored longer than this time, it should be removed and filled with fresh fuel.

CHECK POINTS BEFORE OPERATION



1. Check for loose bolts, nuts and fittings.
2. Check the air cleaner for dirt. Clean the air filter of all dirt, debris etc. before operation.
3. Check to be sure air intake screen on engine is securely in place and clean.
4. Check oil level.
5. Check that unit has been removed of all debris, leaves, grass, dirt etc.
6. Check to make sure hose is securely attached (clamped tight) to unit.
7. Check to make sure discharge chute will be discharging into a well ventilated enclosed box.



Machines with Wheel Kits - Before starting the machine the back brace should always be in the down position and the pins must be locked in place. When the machine is not attached and the engine is brought up to operating speed, the machine will flip over if the legs are not in the down locked position.

For all machines with or without wheel kit (including Tail Gate Truck Loader)- Never look into discharge hose. Never start or operate machine WITHOUT INTAKE HOSE CLAMPED ONTO MACHINE!!!!!!!!!!

* Avoid wearing loose clothing near intake hose.

* Safety glasses should always be worn when operating machine.

Warning: This unit is designed to be used in conjunction with debris collection box. Never run or operate your Truck Loader without a debris box.

OPERATING INSTRUCTIONS



Like all mechanical tools, reasonable care must be used when operating machine. Inspect machine work area and machine before operating. Making sure that all operators of this equipment are trained in general machine use and safety.

- Pay attention to loosening and overheating of parts. If there is any abnormality of the machine, stop operation immediately and check the machine carefully. If necessary, have the machine serviced by an authorized FRADAN dealer. Never continue to operate a machine which may be malfunctioning.



WARNING DANGER

Never attempt to remove leaves or other debris from any part of the Truck Loader while it is running.



WARNING DANGER

Do no smoke while handling fuel.
Do not refuel a hot or running engine.
Do not fill tank indoors.

Caution: Do not start or run engine indoors as poisonous carbon monoxide is emitted.
Do not operate in un-ventilated area.



The engine exhaust from this product contains chemicals
Known to the State of California to cause
cancer, birth defects, or other reproductive harm.



Helpful Hints

- This machine has been designed for two methods of vacuuming debris.
 1. The operator firmly grasps the handle of the Intake Nozzle and move the nozzle back and forth in a sweeping motion over the debris.
 2. Lay Intake Nozzle horizontally on the ground. By placing the nozzle in this position, debris can be raked into the nozzle by the operator.
- While large amount of debris can be vacuumed quickly with this machine, caution must be taken to avoid blocking the airflow into the nozzle.
- Periodically rotating the Intake Nozzle with respect to the Hose will allow hose to wear more evenly, increasing the life of your hose.
- To save time and effort, gather debris into piles so unit can collect debris more efficiently.
- To get maximum performance out of unit we recommend the following:

- Dry Debris
 - ★ Run engine at approximately half throttle; this will help reduce excessive wear and tear on unit
- Frozen Debris and rocks may NEVER be vacuumed up will cause damage to the machine
- Wet Debris
 - ★ Run engine at full throttle

UNCOUPLING UNIT FROM TOWING VEHICLE

- Drop rear support leg to lowermost position and secure with clevis and hitch pin. Note: Failure to follow this step can result in unit rollover and serious personal injury and unit damage, **See Figure A.**

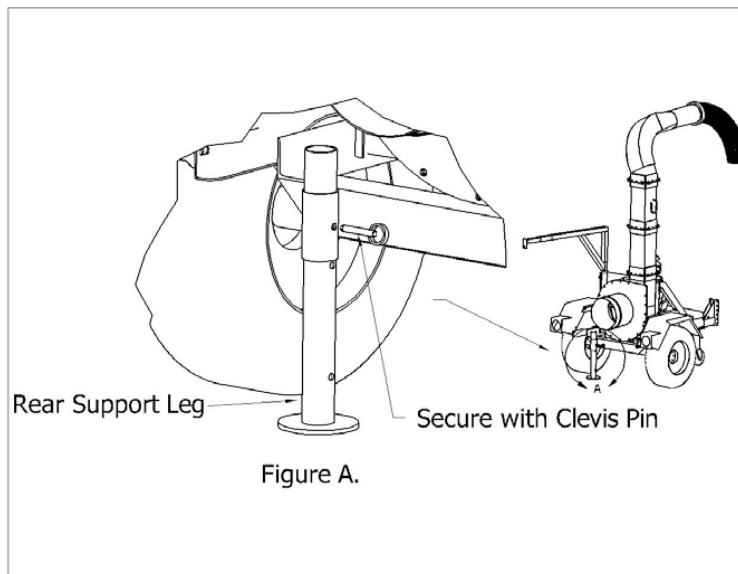

- Disconnect taillight/brake light plug from towing vehicle receiver.
- Unhook safety chains from rear of towing vehicle.
- Unlatch wheel jack until it is locked into the vertical position, **See Figure B.**

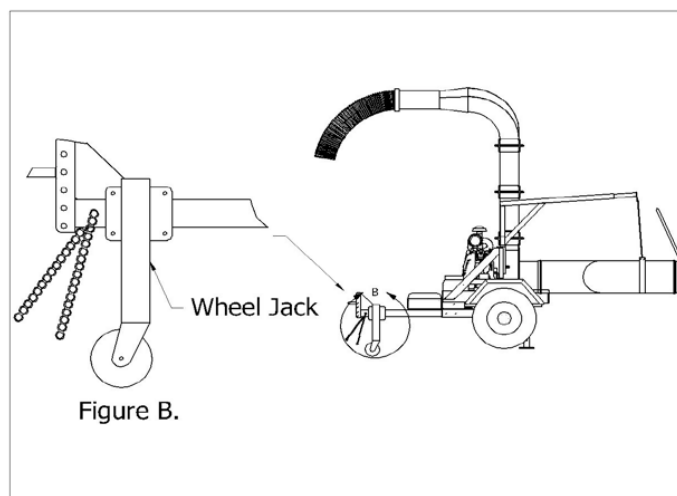

- Unlatch ball hitch/ pintel hook receiver lever on unit up.
- Crank down wheel jack until ball hitch/ pintel hook receiver on unit clears ball hitch/ pintel hook on towing vehicle.
- Pull vehicle away from unit.

CAUTION

: When unit is parked or disconnected from vehicle, lock the rear support leg in lowest position. This will prevent the unit from rolling over.

TRANSPORTATION

CONNECTING UNIT TO TOWING VEHICLE

1. Disconnect chain that is attached to band hose support
2. Hang nozzle onto discharge hook (Hose should be approximately 2 feet above ground)
See Figure C.

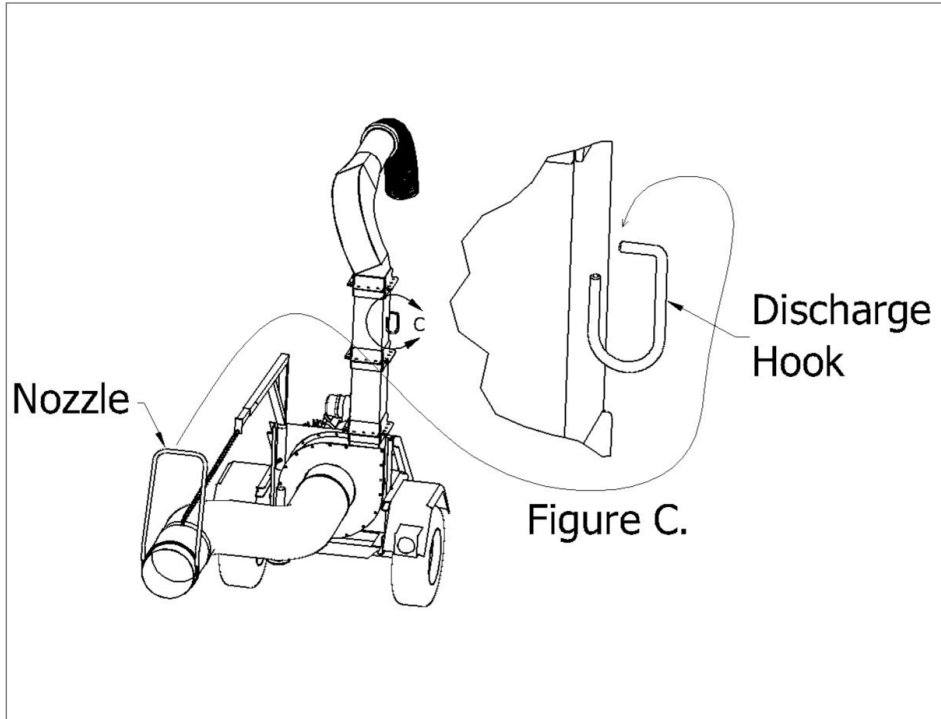

3. Remove clevis and hitch pin from boom assembly.
See Figure D.

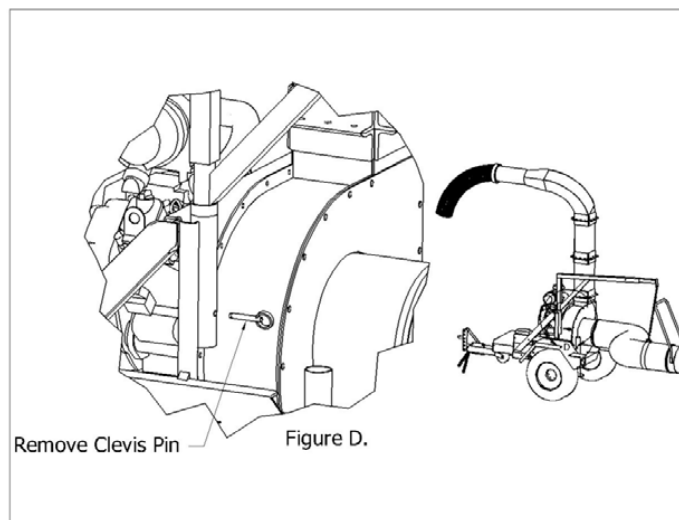

4. Rotate the boom 180 degrees. (Boom should be positioned in direction of travel).
See Figure E.

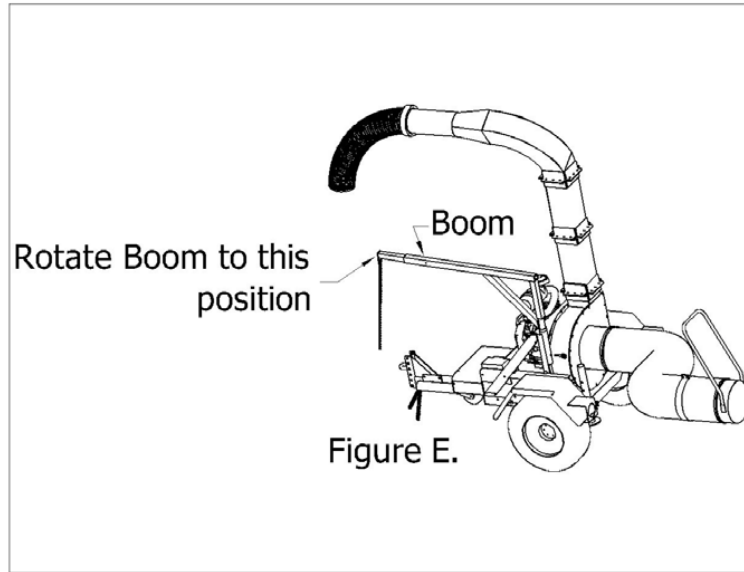

5. Secure clevis and hitch pin firmly. This will prevent boom from rotating while traveling.
6. Securely attach unit to ball/ pintel hitch.
⚠ Warning Danger: Confirm Ball/ Pintel hitch is properly secured. Unit will detach from vehicle if not properly secured.
7. Attach safety chains and connect electrical light connection.
 - Match the trailer's connector to the towing vehicles socket.
8. Raise rear support leg into the upright position.
See Figure F.

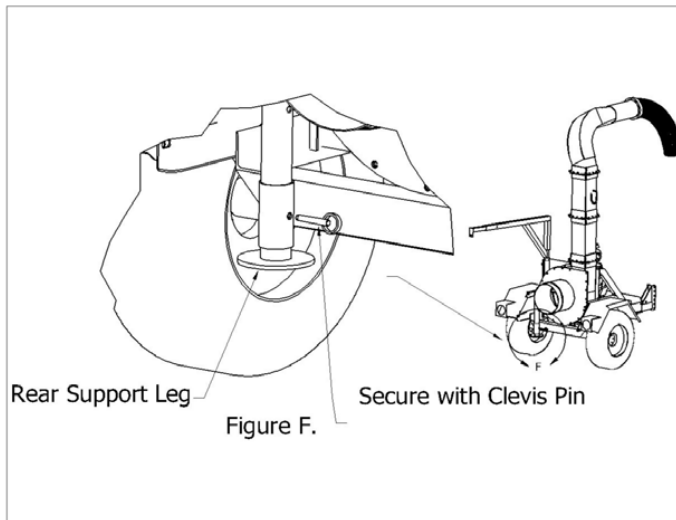

9. Crank up the wheel jack stand and unlatch and rotate wheel jack until it is locked in its horizontal position. See Figure G.

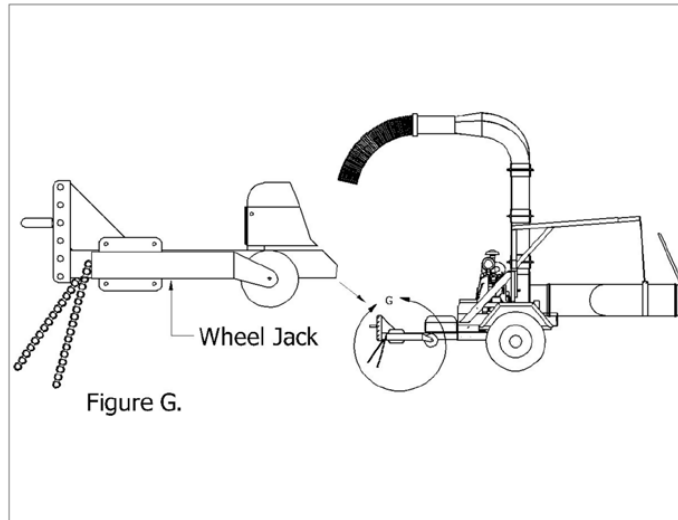

Do not exceed 35 M.P.H when transporting the truck loader. High speed driving and poor road condition can result in injury or death and/or damage to the unit or property.



MAINTANCE INSTRUCTIONS



Any adjustments needed should be performed by a qualified mechanic and made while engine is not running.

General Maintenance

Before proceeding to adjust or repair the machine, be sure to stop the engine and detach all spark plug caps from the spark plugs. (Remember there are multiple spark plugs)

While engine is not running:

1. Clear intake screens on housing and engine throughout use.
2. Keep the blower, drive train and especially the engine air screen and cooling fins clean and free of grease, grass and leaves to reduce the chance of fire and to permit proper cooling.
3. Inspect machine for loose bolts before starting the engine. Repair or replace worn, damaged or missing components promptly.
4. Use only recommended parts, fluids and lubricants specified by engine manufacture. See engine manual.
5. Check at regular intervals and maintain tire air pressure according to pressure indicated on tire sidewall.
6. Check at regular intervals wheel lug nuts are secure and properly tightened.
7. **Keep air filters clean.** Always refer to engine manual regarding engine maintenance.

NOTE: Lead –acid batteries generate hydrogen and oxygen gases which form an explosive mixture. Keep sparks and flames away at all times.

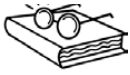

Safety Rules and Precautions for Maintaining Unit

- ☑ Use only Fradan original equipment parts when servicing the unit. This will ensure safe and proper performance of your product. These parts are available from your dealer. The use of any other accessories or attachments may cause a potential hazard or injury to the user, damage to the machine and void this warranty.
- ☑ Make periodic inspections to assure safe and efficient operation. For a thorough inspection of your machine, please contact a FRADAN dealer.
- ☑ Never change attachments or make any adjustments, repairs or replacements until the unit is completely shut down and the battery is disconnected.



Use only a qualified mechanic for any adjustments, disassembly, or any kind of repair.



STORAGE

Never store engine indoors or in enclosed poorly ventilated areas with fuel in tank, where fumes may reach and open flame, spark or pilot light, as in furnace, water heater, clothes dryer or other gas appliance.

It is recommended to disconnect battery when storing unit.

When the machine is placed in storage for a long time, drain fuel from the fuel tank and carburetor, clean the parts, move the machine to a safe place and confirm that the engine is cooled down.

If engine is to be unused for 60 days or more, prepare as follows:

- Be sure engine is cool. Do not smoke. Remove all gasoline from carburetor and fuel tank to prevent gum deposits from forming on these parts and causing possible malfunction of engine. Drain fuel outdoors, into an approved container, away from open flame. Run engine until fuel tank is empty and engine runs out of gasoline.
- Note: Fuel stabilizers may be used, refer to engine manufacture's owners manual.

TROUBLE SHOOTING



Use only a qualified mechanic for any adjustments, disassembly, or any kind of repair.



Fradan Manufacturing Corp.
www.fradanpower.com